

Float Level Switch



Series

LC-30 / LC-31 / LC-M11 / LC-M12

User's Manual

RECEPTION

Check that the level instrument is mechanically correct by means of the following inspection:

- The float (4) slides smoothly along the rod (3) (do it carefully by hand in moving the float up and down).
- The rod (3) does not have any shock and is not bent.
- The bottom float stop (7) at the rod is in place.

Check with a multimeter that when the float slides along the rod, the reed switch is activated in changing the output from NO to NC or vice versa (depending on the wiring according to attached diagram).

Check that the switching points correspond to the required ones.

Check that the float density is inferior than the density of the liquid and that the float is in the correct position (the mark UP engraved at the top of the float indicates that this side of the float must be up).

INSTALLATION

The mounting of the level switch is vertical. The float level varies accordingly with the level of the liquid.

Mount the seal on the flange or the coupling thread.

Introduce with care the float through the mounting hole until the flange or coupling thread couples with the tank. Fix the flange with the appropriate nuts & bolts.

You could mount, if the installation so require, the float by the inside of the tank, in removing the bottom float stop (7).

In the case of a coupling thread, turn until tight. **Do not apply torques greater than 60 Nm.**

REED SWITCHES

The LC's series has two types of contacts for level indication, RSC and Bi-stable RBC. The difference is in the status of the contact once the float has passed the contact.

Series RSC

The RSC is a reed switch without "memory". It is only activated in presence of the magnetic field of the float. If the float moves away from position of the switch, the switch returns to it's non-active position, which is the same for the float being above or below the switch.

This system provides an indication of when the level is at the same position as the reed switch

but will not provide an indication of the level away from this point. That is, it provides an indication of actual level but not high or low level.

Series Bi-stable RBC

The bi-stable RBC reed switch remains in it's switched position after the float has passed. It will remain in one position when the float is below and remains in the opposite position while the float is above the reed switch. This provides a High/Low indication but not indicate the exact position of the level.



Technical Data

- Mounting: Vertical.
- Connection: DN-40 PN-16 DIN 2501 Flange.
R 1½" BSP thread.
(Others available on request).
- Maximum length: AISI-316 ... 6000 mm.
PVC, PTFE ... 2500 mm.
PVC, PTFE ... 6000 mm
(internal AISI-316).
- Precision: ± 2 mm.
- Hysteresis: ± 4 mm.
- Working pressure:
PN-16 AISI-316.
PVC, PTFE with internal AISI-316 tube.
PN-10 PVC, PTFE.
- Liquid temperature:
-20°C...+150°C en AISI-316, PTFE.
0°C...+50°C PVC.
- Ambient temperature:
-20°C...+60°C AISI-316, PTFE.
0°C...+50°C PVC.
- Liquid density: From 0,45 to 3 kg/l.
- Liquid viscosity: Maximum 1500 cSt.
- Contacts: Reed 1 A 220 V.
(maximum 9 with minimum separation
of 20 mm)

Conforms with Directive 73 / 23 / CEE

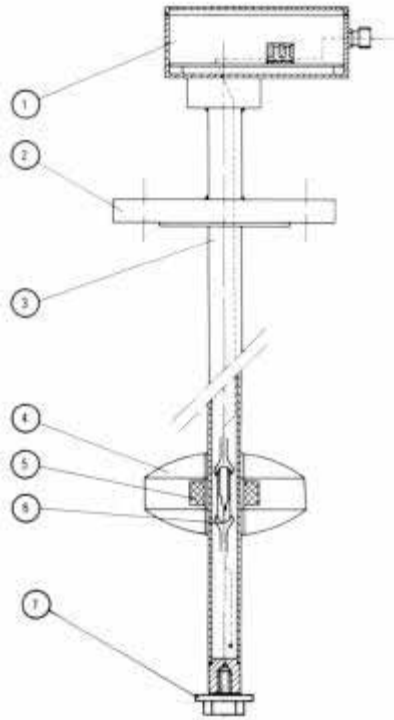

CONSTRUCTION

No.	Piece	Materials		
		LC-.../INOX	LC-.../PVC	LC-.../PTFE
1	Enclosure	DIN 43650/ Aluminium	DIN 43650/ Aluminium	DIN 43650/ Aluminium
2	Connection	AISI-316	PVC	PTFE
3	Rod	AISI-316	PVC	PTFE
4	Float	AISI-316	PVC	PTFE
5	Magnet	Alnico	Alnico	Alnico
6	Reed switch	-	-	-
7	Float stop	AISI-316	PVC	PTFE

OPERATION

Inside the guide tube, reed switches are mounted at the alarm/control points..

As the float passes the position where a reed switch is located, the magnetic field from the float activates the switch.
The maximum number of alarm or control points is 9.

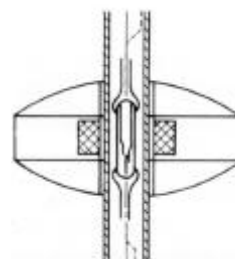

DIMENSIONS

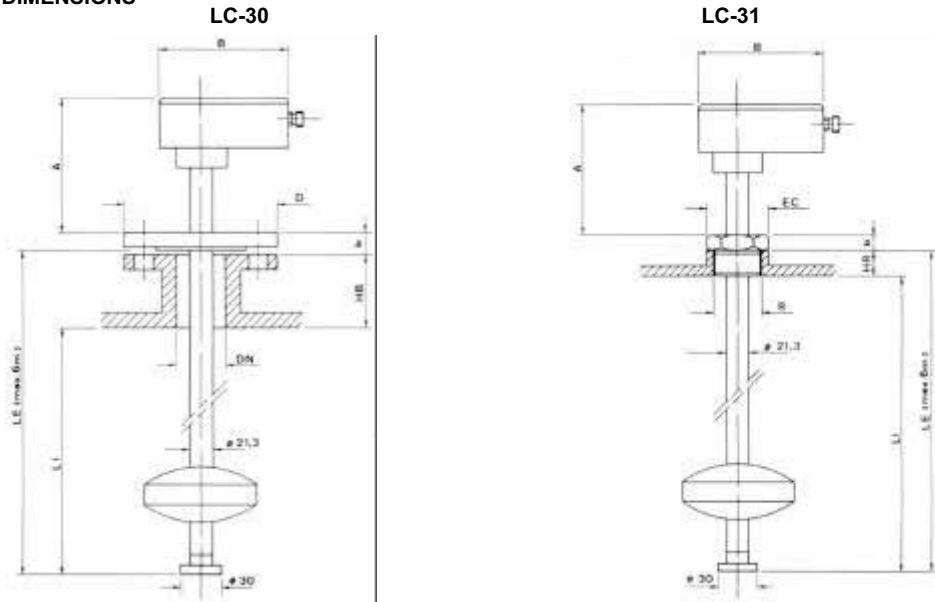

LC-30

DN	PN	D	k	g	Lxno.	b	A	B	HB	LE	LI
25*	40	115	85	68	14x4	18	160	125			
40	16	150	110	88	18x4	18	160	125			
100*	16	220	180	158	18x8	20	160	125			
150*	16	285	240	212	23x8	22	160	125			

Related to the individual measuring range.

(* on request)

LC-31

R	EC	b	A	B	HR	LE	LI
1 1/2"	60	22	160	125	30		Related to range

WIRING

The wiring should be made according to the attached diagram.

When using inductive loads, such as relays or electro-valve coils, surge arresters should be installed to protect the reed contacts.

With a dc supply, a diode should be used.

For an ac supply, an RC circuit can be used as shown, although a varistor (VDR) is better and is easier to select the right value.

The VDR should have a breakdown voltage greater than 1.5 times the rms voltage.

The standard varistor ratings specify the rms working voltage for the varistor, for example a S05K25 varistor will be for 25 V_{rms} working and will have a breakdown voltage of 39 V at 1 mA.

DIMENSIONS

LC-M12

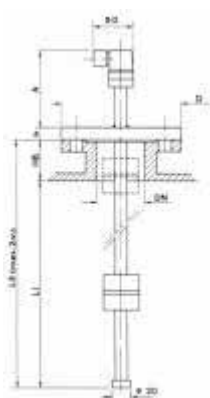

LC-M11

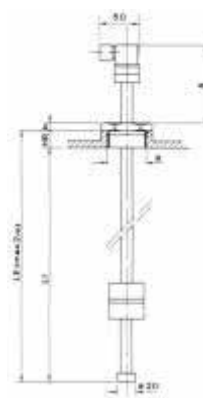

LC-M12

DN	PN	D	k	g	Lxno.	b	A	HB	LE	LI
25	16	115	85	68	14x4	18	100	Related to range		

LC-M11

R	EC	b	A	HR	LE	LI
1 1/2"	60	22	100	30	Related to range	

WARRANTY

Tecfluid S.A. GUARANTEES ALL ITS PRODUCTS FOR A PERIOD OF 12 MONTHS, maximum 18 months after consignment, against all defects in materials and workmanship.

This warranty does not cover failures which can be imputed to misuse, use in an application different to that specified in the order, the result of service or modification by un-authorized persons, bad handling or accident.

This warranty is limited to cover the repair or replacement defective parts which have not been damaged by misuse.

This warranty is limited to the repair of the equipment and all further and eventually following damages are not covered by this warranty.

In the event of consignment of equipment to our factory, this should be done with the equipment well packed and prepaid transport, clean of any liquids, grease or hazardous materials. Tecfluid S.A. will not accept any responsibility for damage done during transport. Together with the equipment, a note should be enclosed indicating the failure observed, the name, address and telephone number of the sender.

TECFLUID, S.A.
 Narcís Monturiol, 33
 E-08960 Sant Just Desvern
 Tel. + 34 93 3724511 - Fax + 34 93 4734449
 E-mail: tecfluid@tecfluid.com
 Internet: www.tecfluid.com

TECFLUID, S.A. reserves the right to modify the above specifications without notice.